

# LB-Series

## Heavy Duty Boring Bars

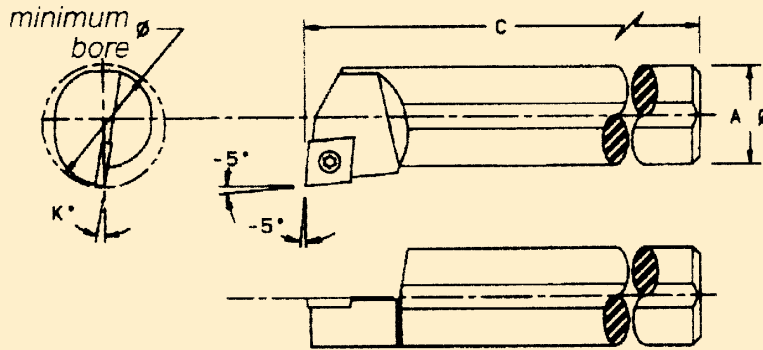

Catalog Number	Shank (A)	Min. Hole	OAL (C)	K	Insert	Screw
LB-ISR-.375-CC2-1.5	.375"	.420"	6"	10°	CCMT-21.52	TX-2545-65
LB-ISR-.375-CC2-1.5wc						
LB-ISR-.437-CC2-1.75	.437"	.482"				
LB-ISR-.437-CC2-1.75wc						
LB-ISR-.50-CC2-2	.500"	.550"				
LB-ISR-.50-CC2-2wc						
LB-ISR-.625-CC2-2.5	.625"	.675"	8"	CCMT-32.52	TX-0832-3	
LB-ISR-.625-CC2-2.5wc						
LB-ISR-.625-CC3-2.5						
LB-ISR-.625-CC3-2.5wc						
LB-ISR-.75-CC3-3	.750"	.800"	10"			
LB-ISR-.75-CC3-3wc						
LB-ISR-1.0-CC3-4	1"	1.05"				
LB-ISR-1.0-CC3-4wc						

\* 'wc' = Carbide shank

- HSS and carbide shanks available with coolant-fed options
  - Adjustable boring bars also offered
- Our diamond tipped inserts work well in non-ferrous materials

