

# LP-Series

Flexible tool for secondary milling operations

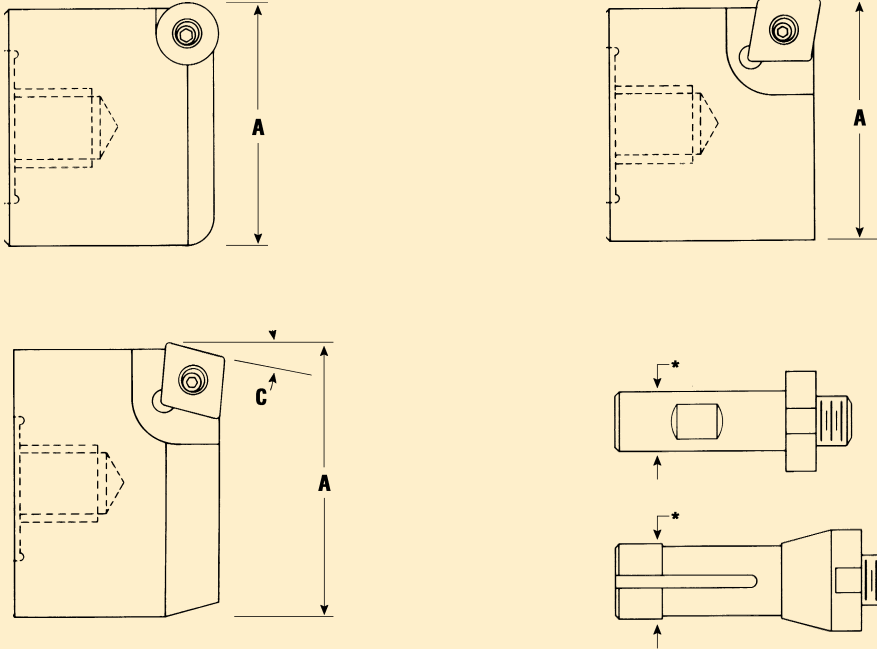

Cut Diameter (A)	Catalog Number	Shank	Lead Angle (C)	No. of Inserts	Insert	Screw
2"	LP-SNR-2-RN4-0-S(3)	*	0-deg.	3	RNMG-43	DIS-4-10
2"	LP-SNR-2-CN4-0-S(3)	*	0-deg.	3	CNMG-432	DIS-4-10
2"	LP-SNR-2-CN4-15-S(3)	*	15-deg.	3	CNMG-432	DIS-4-10
2"	LP-SNR-2-SN4-45-S(3)	*	45-deg.	3	SNMG-432	DIS-4-10
3"	LP-INR-3-RN4-0-5(4)	1.25"	0-deg.	4	RNMG-43	DIS-4-10
3"	LP-INR-3-CN4-0-5(4)	1.25"	0-deg.	4	CNMG-432	DIS-4-10
3"	LP-INR-3-CN4-15-5(4)	1.25"	15-deg.	4	CNMG-432	DIS-4-10
3"	LP-INR-3-SN4-45-5(4)	1.25"	45-deg.	4	SNMG-432	DIS-4-10

\* Screw-On Shanks Available

- 1" Weldon Type Catalog #LE-B3499
- 3/4" Weldon Type Catalog #LE-B3498
- R-8 Type Catalog #LE-B3497

- Morse taper and catV shanks also available
- Special diameters upon request

